

Secure Doc Executive

for fire protection of valuables

How do you protect your irreplaceable documents from fire? The Secure Doc Executive will protect your private things, valuables and documents from fire.

The Secure Doc Executive offers fire protection classification for paper, which means that documents stored in the safe will be protected against fire for 60 minutes. The Secure Doc Executive is ideal for at home and in any business environment. The safes are suitable for secure storing of all kinds of personal belongings, like insurance documents, passports, bank-books, income-tax reports, contracts, receipts, etc.



Models

The Secure Doc Executive is available in four models, all designed to protect your documents and belongings from fire. Model 30 and 36 are compact designs, but offer very efficient storage capacity. Model 52 and 76, the larger safes in the range, are suitable for storing binders vertically.

Locking

The safes are provided with an user friendly electronic pin-code lock or security key lock. The electronic lock provides the possibility to program two user codes and has a sophisticated design. Modern technology provides a hold up function when an incorrect code has been entered five times.

Certification

The Secure Doc Executive range is tested and certified to NT Fire 017 – 60 Paper and UL 72 Class 350 – 1 Hour Fire and Impact.

Additional features

For floor anchoring the safes are provided as standard with an anchoring hole in the base. Also as standard, the safes are delivered with a shelf and / or special tray to store small items. Additionally model 76 is equipped with a lockable drawer.

Design

The safes range will complement any user environment and are supplied in a modern two-tone colour finish of light grey and dark grey light.

Secure Doc Executive

Models

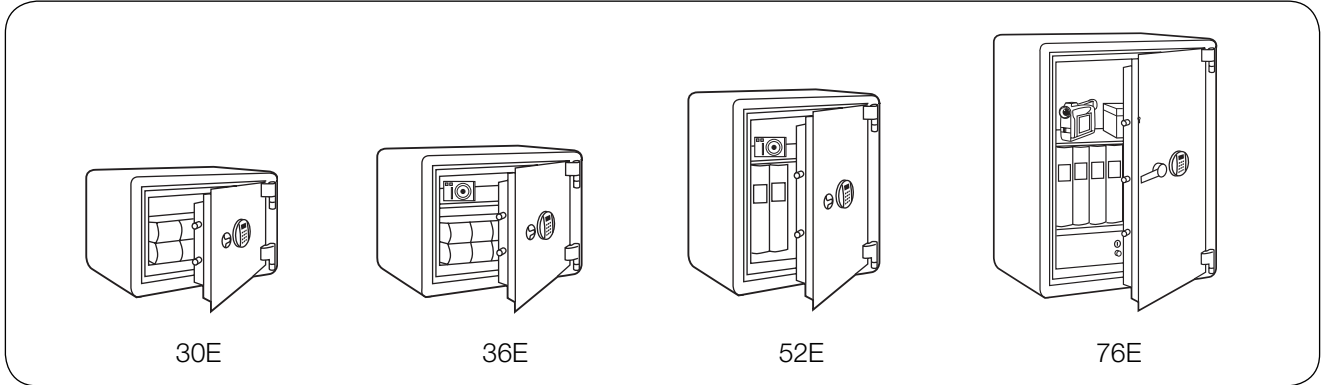

SLGB.1006.R3

Product data

Key lock

Model	Article No.	External dimensions (mm)			Internal dimensions (mm)			Volume (litres)	Weight (kg)	Fittings (qty)		
		Height	Width	Depth	Height	Width	Depth			Shelf	Tray	Drawer
SDE-30K	SL03620	296	390	320	215	310	215	15	27	1	-	-
SDE-36K	SL03621	360	424	458	245	325	320	25	34	-	1	-
SDE-52K	SL03622	520	410	445	415	305	320	41	56	1	1	-
SDE-76K	SL03623	756	555	508	515	385	335	67	130	1	-	1

Electronic lock

Model	Article No.	External dimensions (mm)			Internal dimensions (mm)			Volume (litres)	Weight (kg)	Fittings (qty)		
		Height	Width	Depth	Height	Width	Depth			Shelf	Tray	Drawer
SDE-30E	SL03600	296	390	320	215	310	215	15	27	1	-	-
SDE-36E	SL03601	360	424	458	245	325	320	25	34	-	1	-
SDE-52E	SL03602	520	410	445	415	305	320	41	56	1	1	-
SDE-76E	SL03603	756	555	508	515	385	335	67	130	1	-	1

SecureLine policy is one of constant improvement. The above specification may therefore be altered without prior notification.

www.Secure-Line.net

Authorised dealer: