

Secure Doc Office

for fire protection of paper documents

Are you looking for a cabinet that will protect your valuable documents from fire? Well, Secure Doc Office is what you are looking for. It will protect your paper documents from severe fires.

The Secure Doc Office range has a fire protection classification of 120 Paper, which means that documents stored in the cabinets will be protected against fire lasting 2 hours. Statistics shows that more than 80% of all companies that have been exposed to a fire have reached bankruptcy within 3 years. The Secure Doc Office offers a very high fire protection for documents and ensures continuation of your business.



Models

The Secure Doc Office is available in four models and specially designed for use in office environments. With its large capacity and removable shelves you will always be able to find the optimum storage configuration for binders and documents. Additionally a 'Combi' model is available which combines the storage of paper documents and data media.

Locking

The safes are equipped with an electronic security lock with LCD display as standard. In addition to the normal user code (4-16 digits) the lock provides a master code, log event and anti-spy function.

Certification

The Secure Doc Office range is tested in accordance with NT Fire 017 – 120 Paper, which means that your paper documents are protected even after being subjected to a fire lasting 2 hours. Due to the insulated wall the internal temperature will not raise above 177°C. The Combi-version offers 120 Paper label and 60 Diskette label, both according NT Fire 017.

Additional features

The models are provided with removable shelves as standard to maximize your storage capacity. Furthermore an optional special fire insert is available for storing data media, such as CD/DVD's, backup tapes, etc.

Design

The Secure Doc Office range will complement any user environment and is supplied in a modern light grey finish.

Secure Doc Office

Models

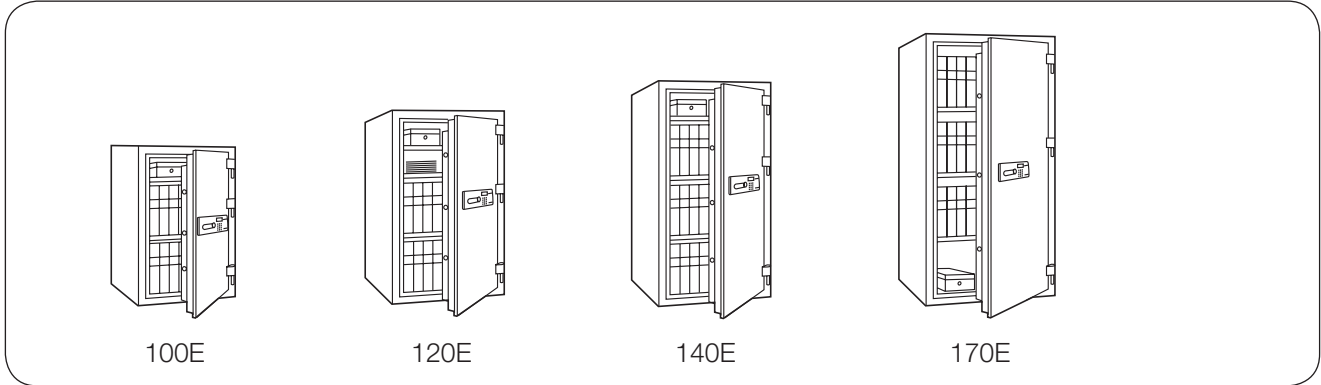

SLGB.1021.R2

Product data

120 Paper

Model	Article No.	External dimensions (mm)			Internal dimensions (mm)			Volume (litres)	Weight (kg)	Shelf (qty)
		Height	Width	Depth	Height	Width	Depth			
SDO-100E	SL04300	1000	600	535	775	445	360	125	210	2
SDO-120E	SL04301	1200	700	635	945	530	460	231	270	3
SDO-140E	SL04302	1400	700	635	1145	530	460	280	335	3
SDO-170E	SL04303	1700	800	635	1445	630	460	420	485	3

Combi – 120 Paper + 60 Diskette

Model	Article No.	External dimensions (mm)			Internal dimensions (mm)			Volume (litres)	Weight (kg)	Shelf (qty)	CD/DVD (qty)	
		Height	Width	Depth	Height	Width	Depth				10 mm case	5 mm case
SDC-120E	SL04050	1200	700	635	580*	400*	300*	60*	294	2*	N/A	N/A
					330**	210**	195**	13**			1**	40

*120 Paper ** 60 Diskette

SecureLine policy is one of constant improvement. The above specification may therefore be altered without prior notification.

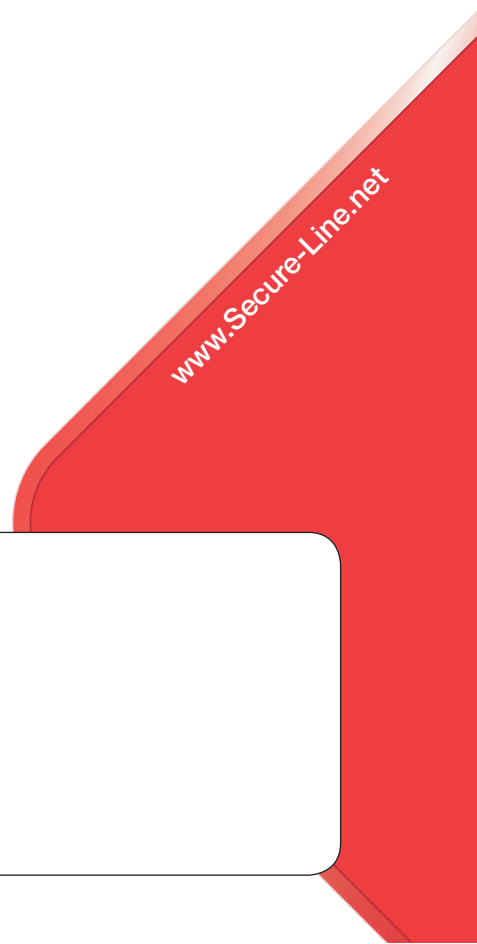

Authorised dealer:

